

Driver: Mike Dunn

Track: Vegas Silver Bowl - Roar Nats.

Air Temp: 95F

Surface Description: Blue/dry/hard w/dust

Avg. Lap Time: 38 sec.

Front Suspension

Shock Spring: Blue

Shock Piston: 53/54

Shock Oil wt: 60 wt.

Shock Length (Center to Center): 102mm

Toe-IN:

Toe-Out: 3 degree

Front Ride Height: Bones just above level

Sway Bar: 2.4mm

Camber: Neg: 2 degrees

Pos:

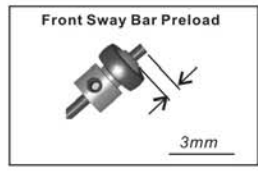
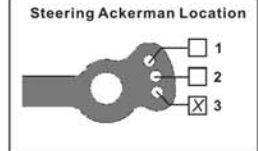
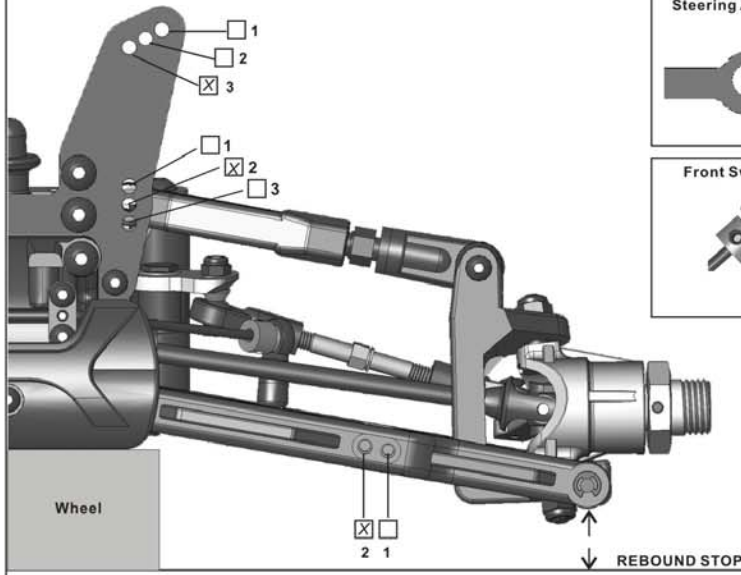
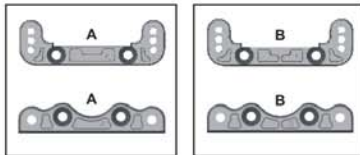
 Camber Block: A/A B/B

Notes:

Rear Suspension

Shock Spring: Blue

Shock Piston: 53/53

Shock Oil wt: 50 wt.

Shock Length (Center to Center): 125mm

Rear Ride Height: Bones level

Sway Bar: 2.8mm

Camber: Neg: 2 degrees

Pos:

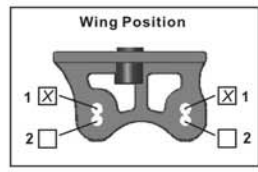
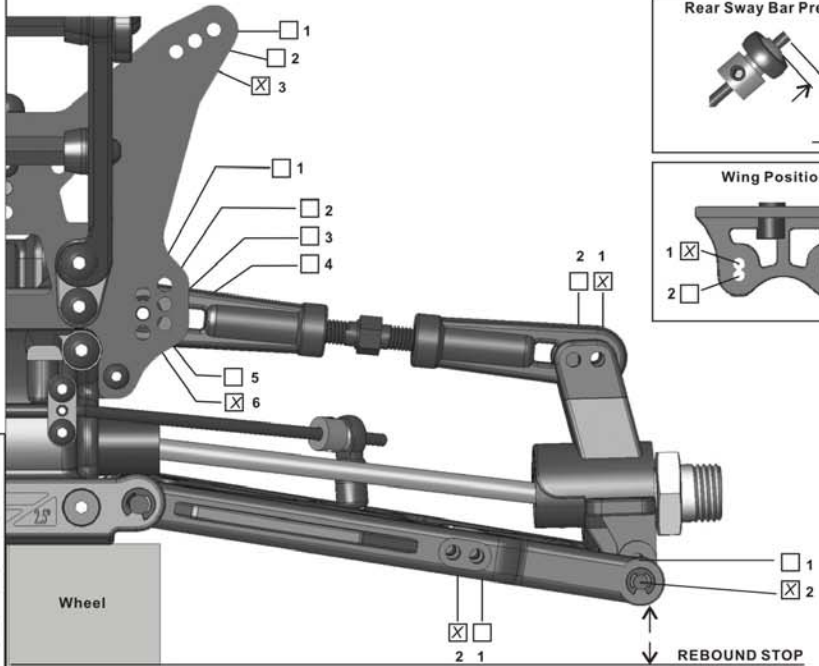
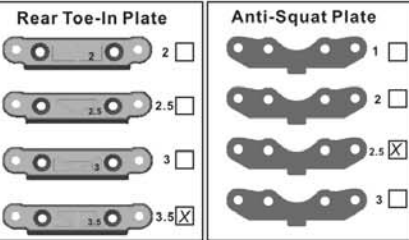
 Rear Hub/Wheelbase: Forward Middle Back

Differentials

Front Type: Standard Oil: 5,000

Center Type: Standard Oil: 7,000

Rear Type: Standard Oil: 2,000

Tires

Front Type: P.L. CrimeFighter Compound: XTR Foam: Stock

Rear Type: P.L. CrimeFighter Compound: XTR Foam: Stock

Note: Outer and inner rows cut off

Engine

Type: RS 5 Coronado

Head Clearance: .021" Pipe: Jammin JP-1

Fuel: O'Donnell % 30 Plug: O'Donnell

Needle (Top): 2 out (Bottom): 11 3/4 out

Note:

Clutch

Shoe Brand: Ofna Compound: Purple Aluminum

Spring Brand: Ofna Tension: Silver Heavy 1.0mm

 Gearing: 13T 14T To 46T 48T

Note: 1/16" hole drilled in each shoe - thru