

Driver: Jay Halsey

 Track: Perris Racepark - Perris, Ca.

 Air Temp: 80F

 Surface Description: Clay - Wet & Dry

 Avg. Lap Time: 13 sec.

## Front Suspension

 Shock Spring: Blue

 Shock Piston: 54/54

 Shock Oil wt: 50 wt.

 Shock Length  
(Center to Center): 102mm

Toe-IN: \_\_\_\_\_

 Toe-Out: 2 degrees

 Front Ride Height: Arms Level

 Sway Bar: None - see note

 Camber: Neg: 2 degrees

Pos: \_\_\_\_\_

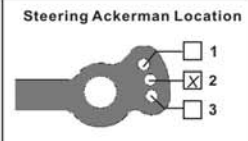
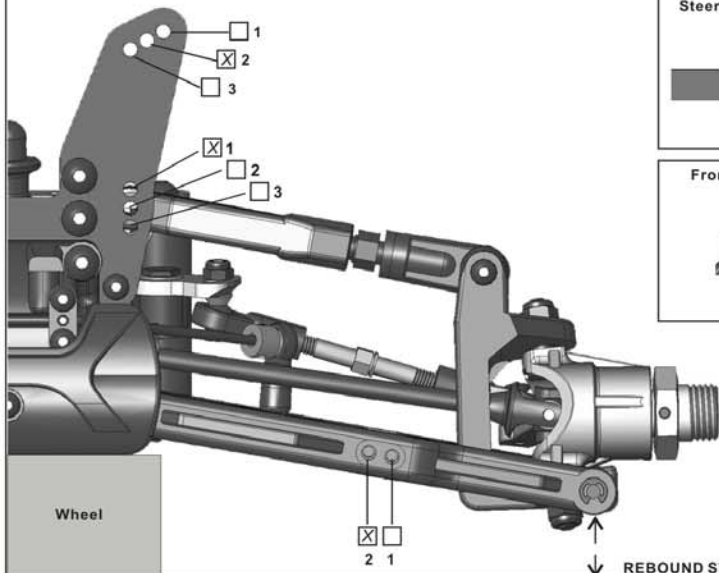
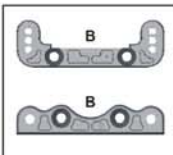
 Camber Block:  A/A  B/B

 Notes: Should try 2mm sway bar, good on wet, pushed on dry

## Rear Suspension

 Shock Spring: Blue

 Shock Piston: 53/53

 Shock Oil wt: 40 wt.

 Shock Length  
(Center to Center): 124.5mm

 Rear Ride Height: Bones level

 Sway Bar: 2.4mm

 Camber: Neg: 2 degrees

Pos: \_\_\_\_\_

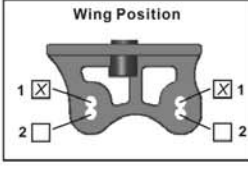
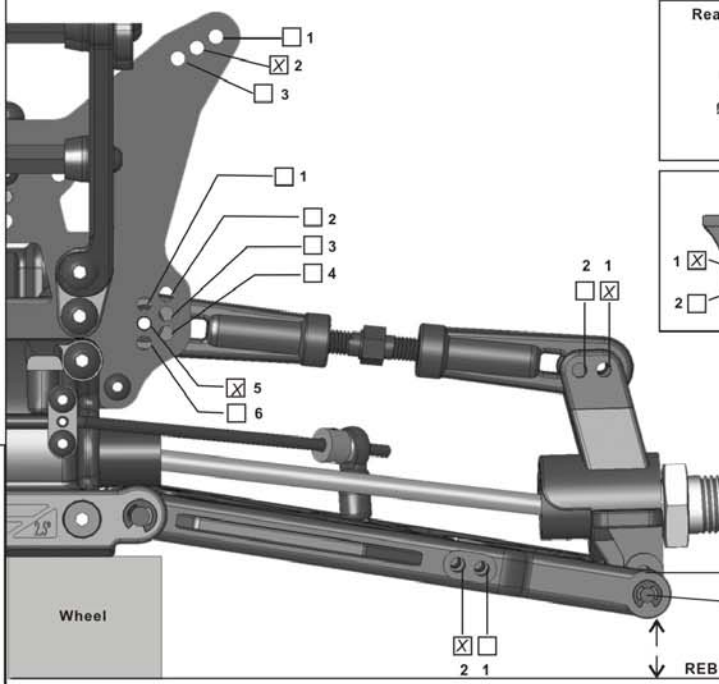
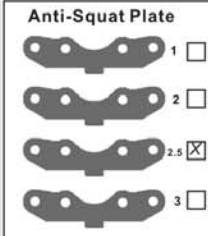
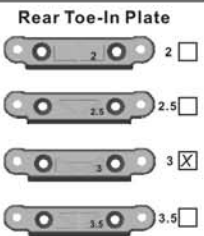
 Rear Hub/Wheelbase:  Forward  Middle  Back

## Differentials

 Front Type: Standard Oil: 5,000

 Center Type: Standard Oil: 7,000

 Rear Type: Standard Oil: 1,000

## Tires

 Front Type: Jammin Shredder Compound: Standard Foam: Stock Stiff

 Rear Type: Jammin Shredder Compound: Standard Foam: Stock Stiff

Note: \_\_\_\_\_

## Engine

 Type: Picco / Ofna BP

 Head Clearance: .025" Pipe: Jammin JP-1

 Fuel: O'Donnell % 30 Plug: O'Donnell

Needle (Top): \_\_\_\_\_ (Bottom): \_\_\_\_\_

Note: \_\_\_\_\_

## Clutch

 Shoe Brand: Ofna Compound: Blue Aluminum

 Spring Brand: Ofna Tension: 1.0mm

 Gearing: 13T 14T To 46T 48T

 Note: Cut 0.030" from leading & trailing edge of shoes.