

Driver: Dean Sexton

 Track: Sun Valley Spdwy - Burbank, Ca.

 Air Temp: 80F

 Surface Description: Clay - Wet & Dry

 Avg. Lap Time: 38 sec.

Front Suspension

 Shock Spring: Blue

 Shock Piston: 1.4mm

 Shock Oil wt: 60 wt.

 Shock Length (Center to Center): N/a

Toe-IN: _____

 Toe-Out: 1 degree

 Front Ride Height: Level

 Sway Bar: 2.3mm

 Camber: Neg: 2 degrees

Pos: _____

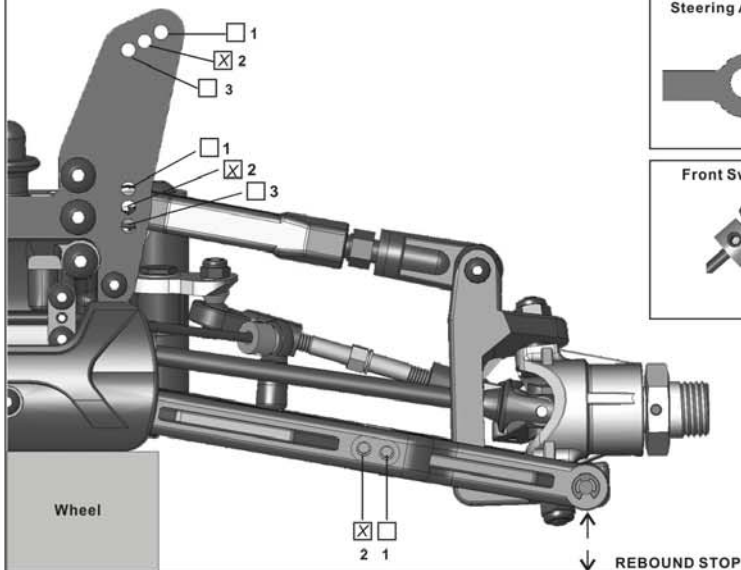
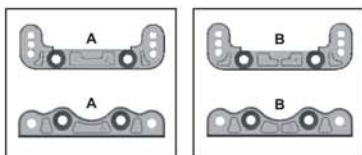
 Camber Block: A/A B/B

Steering Ackerman Location



Front Sway Bar Preload



Notes: _____

Rear Suspension

 Shock Spring: Blue

 Shock Piston: 1.4mm

 Shock Oil wt: 40 wt.

 Shock Length (Center to Center): N/a

 Rear Ride Height: Arms level

 Sway Bar: 2.8mm

 Camber: Neg: 2 degrees

Pos: _____

 Rear Hub/Wheelbase: Forward Middle Back

Rear Toe-In Plate

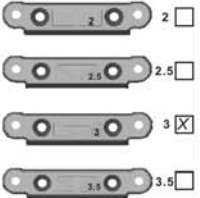

Anti-Squat Plate

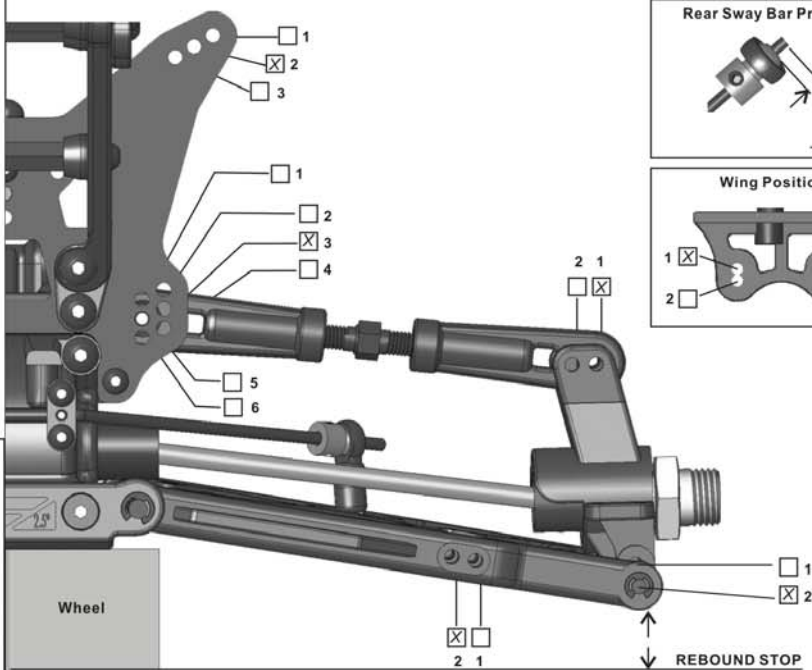
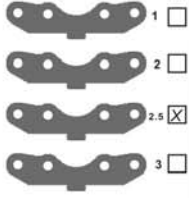

Rear Sway Bar Preload



Wing Position

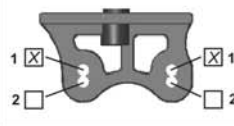

Differentials

 Front Type: Standard Oil: 5,000

 Center Type: Standard Oil: 7,000

 Rear Type: Standard Oil: 2,000

Tires

 Front Type: P.L. CrimeFighter Compound: M2 Foam: Stock

 Rear Type: P.L. CrimeFighter Compound: M2 Foam: Stock

Note: _____

Engine

 Type: RS 5 Corono

 Head Clearance: N/a Pipe: Jammin JP-1

 Fuel: O'Donnell % 30 Plug: O'Donnell

Needle (Top): _____ (Bottom): _____

 Note: Super fast & easy to tune

Clutch

 Shoe Brand: Ofna Compound: Aluminum

 Spring Brand: Ofna Tension: 1.0mm

 Gearing: 13T 14T To 46T 48T

Note: _____