

<b>NAME</b>		<b>TEMP</b>		<b>ENGINE</b>		<b>MUFFLER</b>	
<b>DATE</b>		<b>HUMIDITY</b>		<b>HEAD CLEARANCE</b>	mm	<b>FUEL/TYPE</b>	
<b>TRACK</b>		<b>TRACTION</b>		<b>PLUG NO.</b>		<b>RADIO</b>	

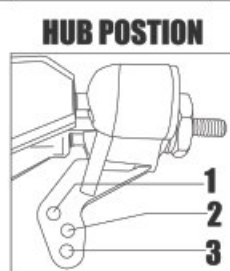

CASTER	ANGLE
3mm	11°
2mm	13°
1mm	15°

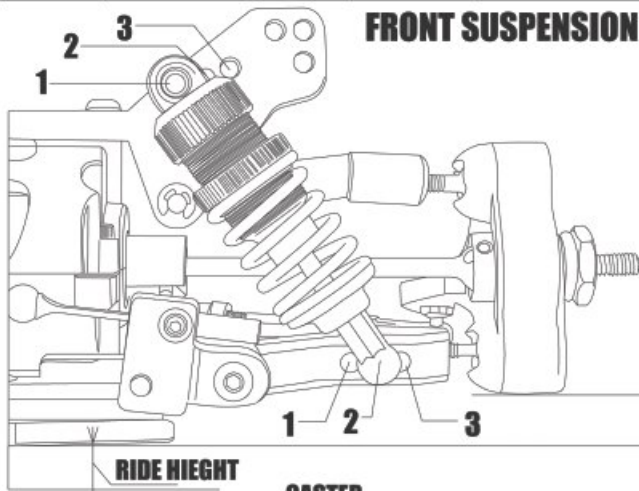
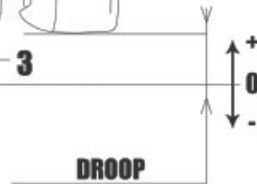
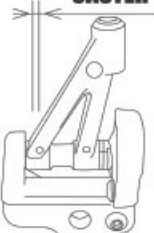

<b>FRONT DIFF.</b>	
<b>GEAR DIFF</b>	
<b>OIL</b>	#
<b>ONE-WAY</b>	

<b>TRACK WIDTH</b>				mm					
<b>RIDE HIEGHT</b>				mm					
<b>CAMBER ANGLE</b>	L	3°	2.5°	2°	1.5°	1°	0.5°	0°	
	R	3°	2.5°	2°	1.5°	1°	0.5°	0°	
<b>SUSPENSION BLOCKS</b>	F	2.5°	1.5°	0°					
	R	2.5°	1.5°	0°					
<b>CASTER ANGLE</b>	3mm	2mm	1mm						
<b>TOE ANGLE</b>				0					
<b>DROOP</b>				mm					
<b>SHOCKTOWER</b>	1	2	3						
<b>LOWER A-ARM</b>	1	2	3						
<b>PISTON</b>									
<b>OIL</b>				#					
<b>SPRING</b>									
<b>SHOCK LENGTH</b>				mm					
<b>ANTIROLL BAR</b>									
<b>TIRE HARDNESS</b>				32	35	37	40	42	45
<b>TIRE TYPE</b>									
<b>TIRE DIAMETER</b>				mm					

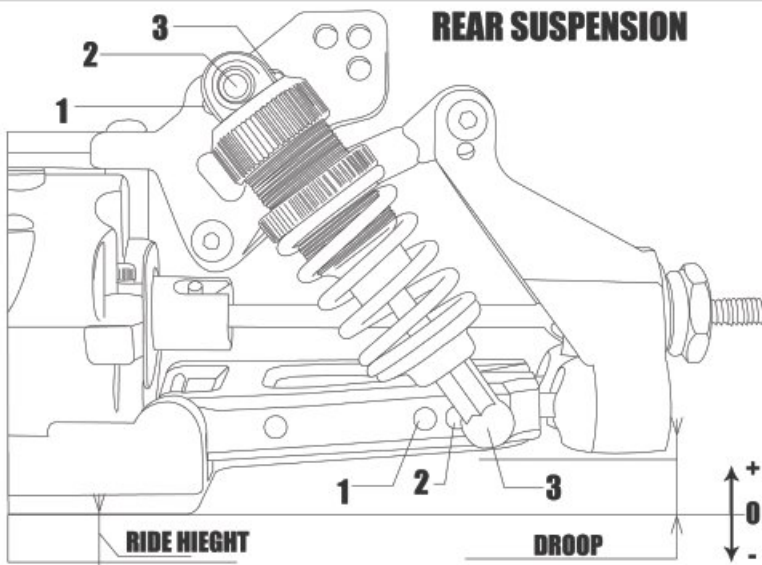

<b>TRACK WIDTH</b>				mm					
<b>RIDE HIEGHT</b>				mm					
<b>CAMBER ANGLE</b>	L	3°	2.5°	2°	1.5°	1°	0.5°	0°	
	R	3°	2.5°	2°	1.5°	1°	0.5°	0°	
<b>SUSPENSION BLOCKS</b>	F	2.5°	1.5°	0°					
	R	2.5°	1.5°	0°					
<b>TOE ANGLE</b>				0					
<b>DROOP</b>				mm					
<b>SHOCKTOWER</b>	1	2	3						
<b>LOWER A-ARM</b>	1	2	3						
<b>PISTON</b>									
<b>OIL</b>				#					
<b>SPRING</b>									
<b>SHOCK LENGTH</b>				mm					
<b>WIRE TYPE</b>									
<b>ANTIROLL BAR</b>									
<b>BLADE TYPE</b>									
<b>TIRE HARDNESS</b>				32	35	37	40	42	45
<b>TIRE TYPE</b>									
<b>TIRE DIAMETER</b>				mm					
<b>TIRE WIDTH</b>									

<b>CLUTCH TYPE</b>		<b>PINIONS</b>	16 17 18 19 / 20 21 22 23 24
<b>CLUTCH SHOES</b>		<b>GEARS</b>	37 38 39 40 41 42 43 44
<b>CLUTCH SPRING</b>		<b>BODY</b>	
<b>CLEARANCE</b>	mm	<b>RACE TIME</b>	
<b>ADJ. NUT</b>	mm	<b>BEST LAP</b>	

**COMMENTS :** \_\_\_\_\_  
 \_\_\_\_\_  
 \_\_\_\_\_

<b>REAR DIFF.</b>	
<b>GEAR DIFF</b>	
<b>OIL</b>	#