

INSTRUCTIONS #35016 NITRO OB-4 1/10 SCALE 2-SPEED TRANSMISSION SET (Shoe Type)

* This professional two speed transmission is only for Nitro OB-4 1/10 Scale OB4 Gas Car Kits.

1 Nitro Ob4 ASSEMBLY OF THE TWO SPEED GEAR (45T GREEN and 41T PINK)

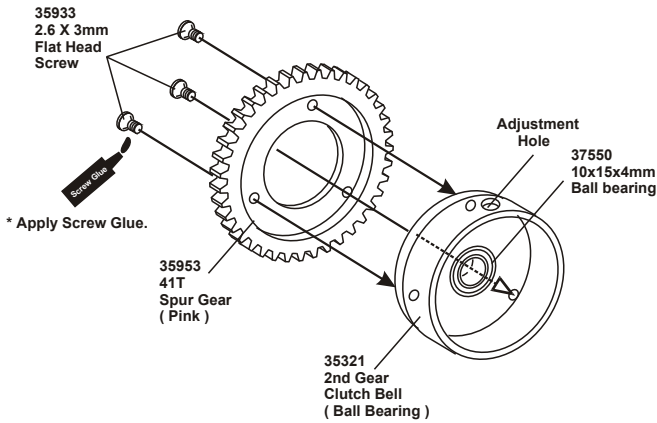

2

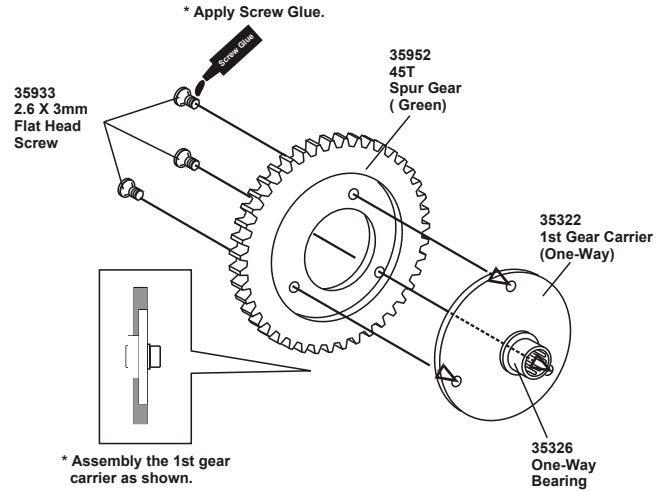

3

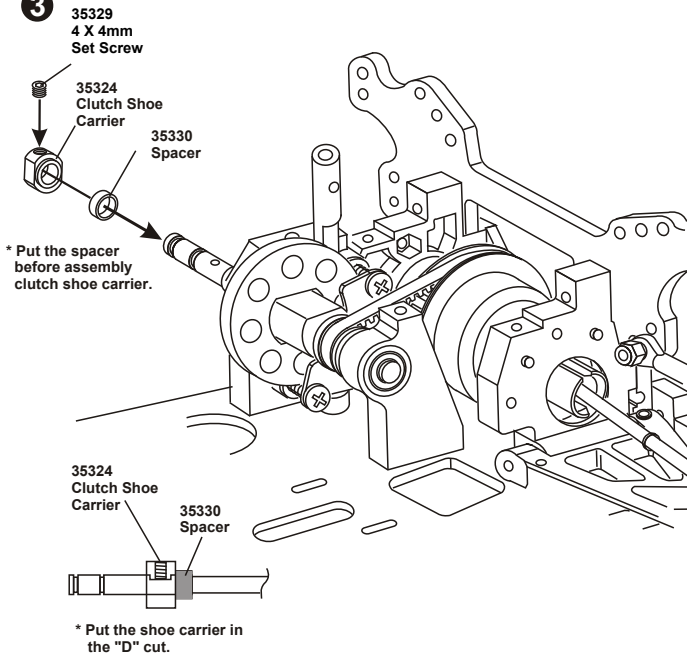

4

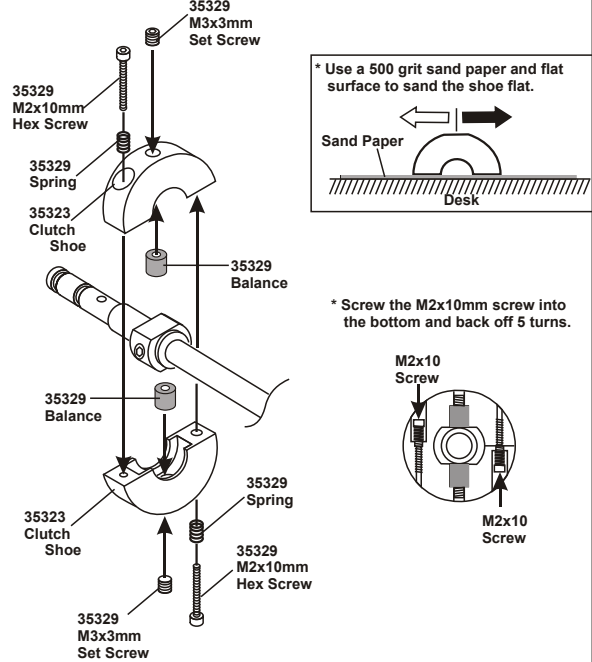

5

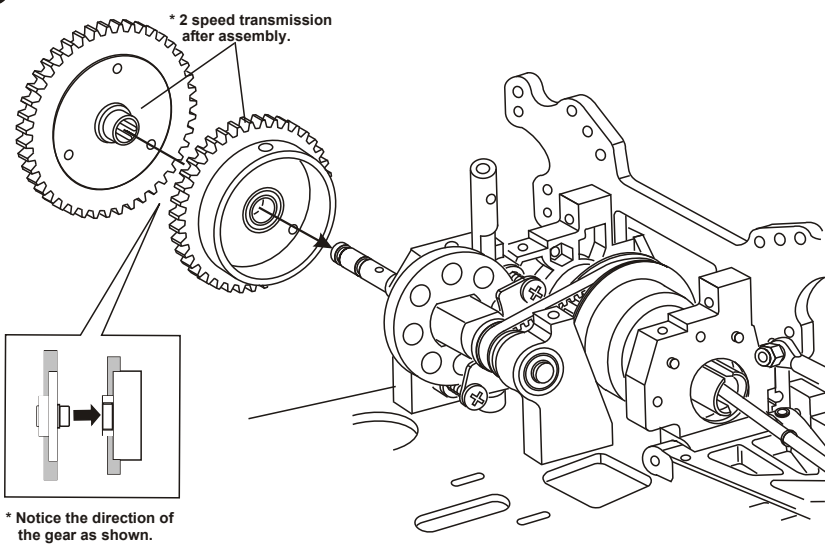

6

* Assembly the parts that come with your kit.

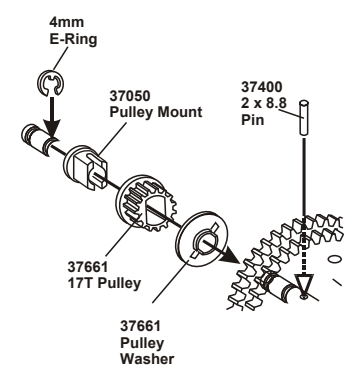

ASSEMBLY OF THE 2 SPEED CLUTCH GEAR

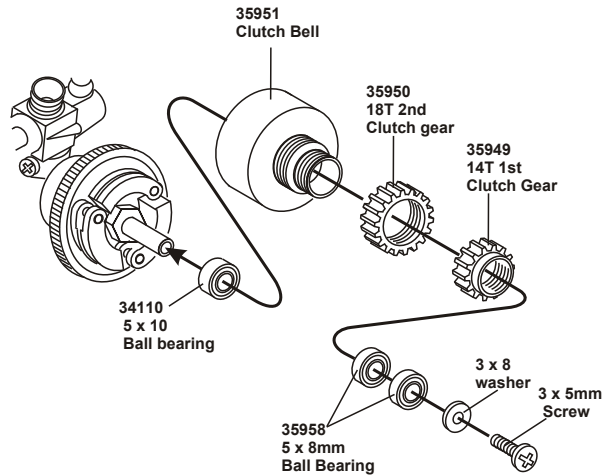

CHECK THE GEAR BACKLASH OF THE CLUTCH GEAR AND SPUR GEAR

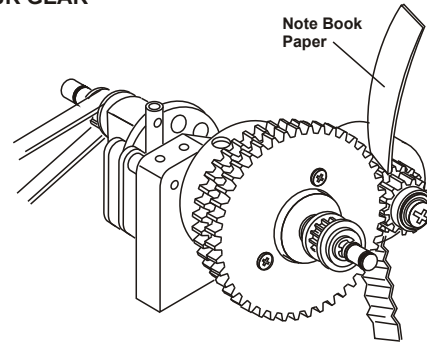

- * Use note book paper to set gear backlash between spur and clutch bell gear. If the space is not correct the spur gear will be damaged.
- * Loosen or tighten your engine mount screw to adjust the mesh of the spur gear and clutch bell.

WHEN USING THE NEW CLUTCH TYPE 2-SPEED TRANSMISSION, YOU WILL NOTICE THE SECOND GEAR SHIFT ACTION IS LESS AGGRESSIVE, LEAVING YOU WITH BETTER CONTROL. OFNA OFFERS A WIDE SELECTION OF GEAR RATIO CHOICES, USE THE BEST RATIO FOR YOUR TRACK LENGTH. REMEMBER DO NOT OVER REV YOUR ENGINE.

ADJUSTING THE SHIFT POINT

* Adjust the engine before adjusting the clutch shift timing. Adjust the engines per engine instruction manual.

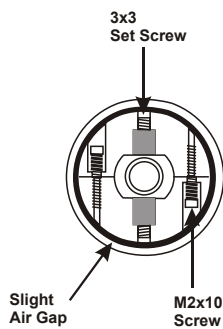

- 1) Use a 1.5mm allen wrench to set the clutch shoe.
- 2) Adjust the 3x3 set screw to set the air gap distance between the clutch shoe and 2nd speed clutch bell.
- 3) Adjusting the M2x10mm screws, will change the shift timing of the clutch shoe. Adjust both screw the same amount of turns

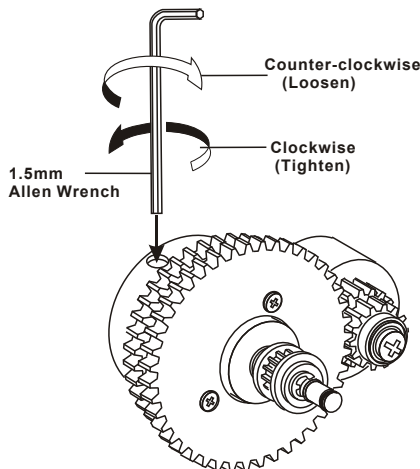

1. Once the engine adjustments have been completed, proceed to the adjustment of the clutch shoe shift timing. (Using a 1.5mm allenwrench to adjust the clutch shoe.)

Note:

Clockwise-----Shift timing will become slower.
Counter clockwise---Shift timing will become quicker.

2. Adjust the clutch shift timing for your track conditions. As you tighten (Clockwise) the 2x10mm screw, the shift timing will become slower. As you loosen (Counter clockwise) the 2x10mm screw, the shift timing will become quicker.
3. Set the shift timing to the track conditions while the car is running.

2 SPEED GEAR RATIO COMBINATIONS

IMPORTANT:

The sum of the spur gear and clutch gear for 1st gear must be equal the sum of the spur gear and clutch gear for 2nd gear be equal.

Example: 1st gear 45+13=58 > Must be equal
2nd gear 41+17=58

(STANDARD)

SPUR GEAR	CLUTCH GEAR (4 tooth difference)			
	45T/41T	13T/17T	14T/18T	15T/19T
44T/40T				
43T/39T				
42T/38T				
41T/37T				

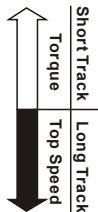

(OPTION)

SPUR GEAR	CLUTCH GEAR (3 tooth difference)			
	45T/42T	13T/16T	14T/17T	15T/18T
44T/41T				
43T/40T				
42T/39T				
41T/38T				

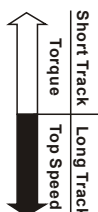

2 SPEED OPTION PARTS

SPUR GEAR(1st):

USA Parts No.	Description
35952	45T Spur Gear (olive)
35965	44T Spur Gear (white)
35934	43T Spur Gear (blue)
35942	42T Spur Gear (red)
35953	41T Spur Gear (pink)

CLUTCH GEAR:

USA Parts No.	Description
35948	13T (1st)
35949	14T (1st)
35940	15T (1st)
35944	16T (1st)
35947	17T (2nd)
35950	18T (2nd)
35941	19T (2nd)
35945	20T (2nd)

SPUR GEAR(2nd):

USA Parts No.	Description
35964	40T Spur Gear (gray)
35935	39T Spur Gear (yellow)
35963	38T Spur Gear (orange)
35943	37T Spur Gear (green)

2 SPEED PARTS

N0.	Description	N0.	Description
35956	Z10 & Rs4 Main Shaft	35324	Clutch Shoe Carrier
35321	2nd Gear Clutch Bell	35325	M2x10mm Hex Screw
35322	1st Gear Carrier		
35323	Clutch Shoes	35326	One-Way Bearing
35329	Spring, Balance, Hex Screw	37550	10x15x4mm Bearing
35330	Spacer, HPI Trany		